

UPM-10PA

SWAN NECK MICROPHONE PANEL

This long Swan neck microphone panels are equipped with balanced cardioid dynamic microphone. It features high gain-before-feedback and an integrated wind and pop screen. Panel has also a PTT button. Simple operation with a robust, compact and attractive appearance. Available with in two versions, UPM-10PA with pre-amplifier to get 0db level signal output, UPM-10HA without preamplifier. Recommended for Wheelhouse and Control Room consoles, bridge wing stations and general use.



FEATURES

- A noise compensated dynamic cardioid microphone capsule is integrated in the swan neck
- Balanced output
- High gain-before-feedback

VARIANTS

- UPM-10PA with PTT button and build in preamplifier
- UPM-10HA with PTT button, without

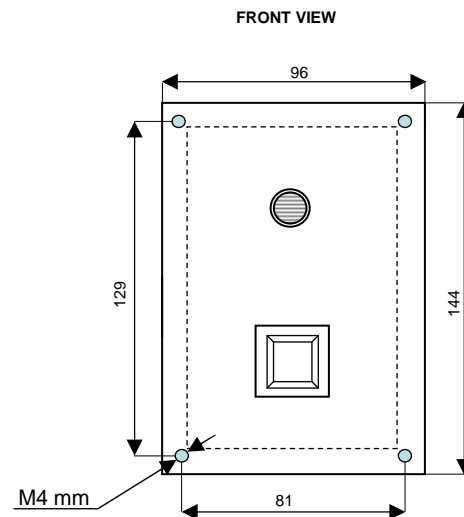

NOTE:
Console cut-out 120 x 75

SIDE VIEW

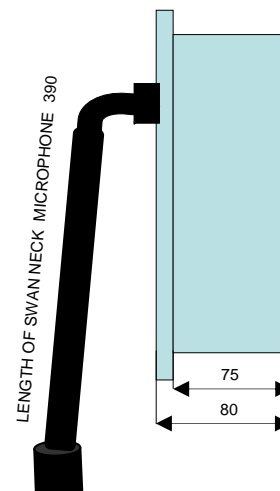

SPECIFICATIONS

Characteristic	Omni Directional
Polar pattern	Cardioid
Nominal Impedance	600 Ω
Sensitivity	-78 dB, ± 3 dB
Button function	Push-To-Talk button
Dimensions (H x W x D)	144 x 96 x 80 mm
Swan neck length	390 mm
Weight of the microphone	700g net
Approvals / Compliance	CE