

MC-001 / 002 / 003 / 004

0.5 Second slave clock with second hand

MC-001 and MC-002 are wall mounting type slave clocks. MC-001 equipped with additional hour hand. MC-003 and MC-004 are panel mounting type slave clocks. MC-003 equipped with additional hour hand.



MC-001/002

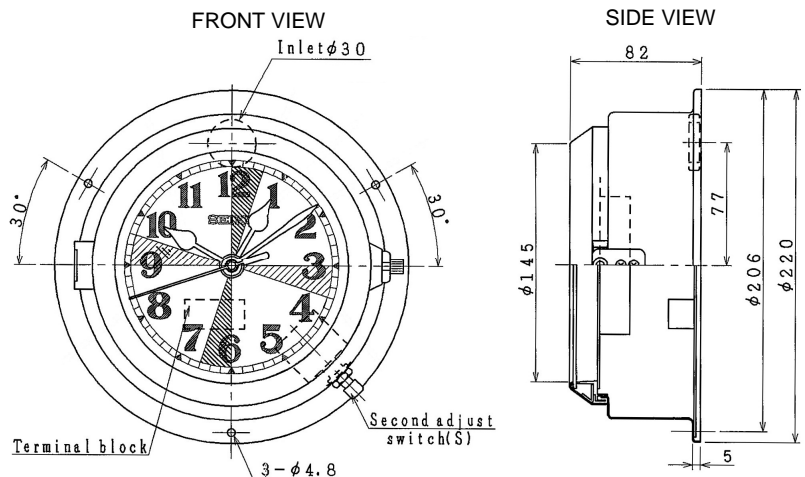

SPECIFICATIONS	
Dimensions (Diameter ϕ , Dial ϕ):	220, 145 mm
Frame material:	Steel
Colour:	Pale green (2.5G7/2) Bluish green (7.5BG7/2)
Hand driving:	Second hand 0.5 second step Minute hand sweep

Wiring diagram

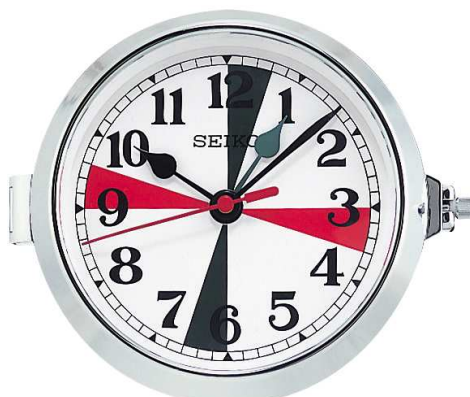
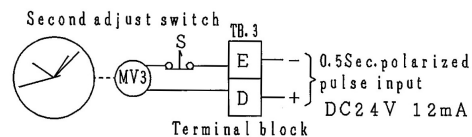

MC-003/004

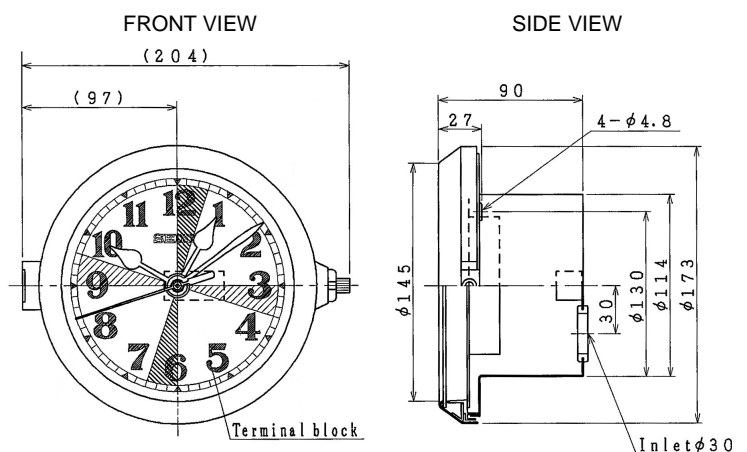

SPECIFICATIONS	
Dimensions (Diameter ϕ , Dial ϕ):	173, 145 mm
Frame material:	Steel
Colour:	Chrome-plated
Hand driving:	Second hand 0.5 second step Minute hand sweep

Wiring diagram

